

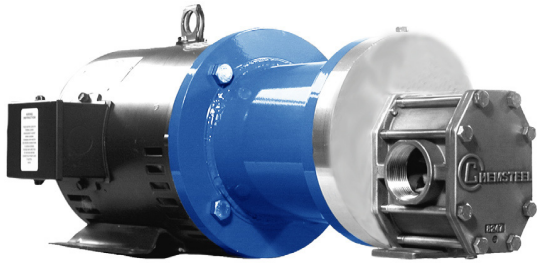

OBERDORFER®

An Ingersoll Rand Business

SM935 METALLIC SEAL-LESS MAGNETIC DRIVE CHEMSTEEL SERIES



A full range of accessories are available including:

- pump mounting foot for use with footless motors
- line mounted pressure relief valves
- pedestal assembly

General Description

Chemsteel pumps are designed to handle highly corrosive liquids that must be pumped under pressure. Manufactured to extremely precise tolerance, the Chemsteel pump line prevents system contamination while maintaining the purity and integrity of the liquid being pumped. Its rugged, three-section, o-ring sealed thru-bolt construction provides ease of servicing and parts replacement.

Helical gearing offers noise reduction by as much as 10db, while the tandem pumps double the output flow for a single fluid, or with isolation, handle other fluids in direct ratio to the first.

Additionally, Chemsteel pumps offer bi-directional operation for applications requiring reversing flow.

MODEL	SM935	
MAXIMUM FLOW (GPM/LPM) @1750 RPM	23 GPM	87 LPM (5.2 m ³ /h)
THEORETICAL DISPLACEMENT	57.8 CC/REVOLUTION	
MAXIMUM DIFFERENTIAL PRESSURE	110 PSIG	7.6 BAR
MAXIMUM SYSTEM PRESSURE	225 PSIG	15.5 BAR
MAXIMUM SPEED	1800 RPM	
MAXIMUM FLUID TEMPERATURE	450° F	232° C
MINIMUM FLUID TEMPERATURE	-50° F	-46° C
NPSHR @ 1750	4 FEET	1.2 M
STANDARD PORT SIZE	1-1/2" FNPT	1-1/2" BSPT
WEIGHT-LESS MOTOR	50 LBS	22.7 KG

Performance

Capacity water at 70° F / 21.2° C

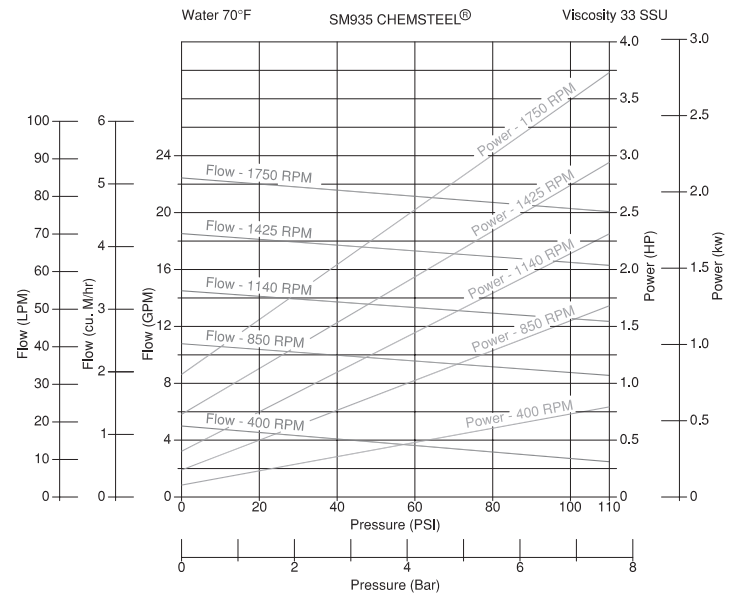

Notes: For continuous service:
 Plastic / Plastic gear combinations are limited to 50 psi or 3.5 bar.
 Metal / Plastic gear combinations are limited to 100 psi or 7 bar.

Specific Solutions

Gear/bearing design allows for “trimming” for optimizing the pump’s maximum flow to reach minimum turndown or to match flow to a specific OEM’s requirement.

Special materials combinations are available for specific liquids:

- 316 stainless or Alloy C housing construction.
- Gears available in metallic 316 stainless, W88 stainless and Alloy C. Also in Teflon®, Ryton® and PEEK®
- Shafts are 316 stainless steel or Alloy C.
- Bearings available in Carbon, Teflon® and Rulon®
- Samarium Cobalt Magnetic Drive.

Life Cycle/Cost of Ownership

Pump design and materials selection, together provide the longest life available from a gear pump. Key attributes include:

- Gear & bearing combinations of metallic and nonmetallic wear surfaces.
- Slotted bearings to lubricate shaft and gear surfaces.
- Hydraulic porting to balance axial thrust and to reduce wear.
- Ample port sizing to reduce the likelihood of cavitation when inlet pressure is marginal.
- Effective housing seals with elastic memory prevent leakage of corrosives.



OBERDORFER®

An Ingersoll Rand Business

Fit

Connections are 1 1/2" female NPT or BSPT, pump hardware is metric and close couple adapters mount to both NEMA and IEC standard motor frame sizes for world wide acceptance. The port size is the same as competitive pumps.

To order a CHEMkit®, simply add a "K" to the end of the model number. A repair kit contains the following parts: bearings, gears, o-rings, shafts, keys, c clips, and retaining ring.

Dimensions

MAG CHEMSTEEL	POWER KIT PART NO.	MOTOR FRAME		*AC	D	2F	H	AE	AD	*O	*XO	*XP
M1	OBMC9H56	56C	INCHES	21.54	3.50	3.00	.34 SLOT	13.06	5.31	6.81	2.25	716
			MILIMETERS	547.1	88.9	76.2	8.6 SLOT	331.7	134.9	173	57.2	181.9
M2	OBMC9J45T	143TC/145TC	INCHES	24.92	3.50	4.00 / 5.00	0.34	13.37	5.31	6.81	2.25	716
			MILIMETERS	633	88.9	101.6 / 127	8.6	339.6	134.9	173	57.2	181.9
M5	OBMC9U90E	IEC 90SC/90LC, B14 FACE	INCHES	23.43	3.54	3.94 / 4.92	.39 SLOT	12.70	5.12 / 4.25	6.81 / 6.53	N/A	5.51
			MILIMETERS	595.1	89.9	100.1 / 125	9.9 SLOT	322.6	130 / 108	173 / 165.9	N/A	140
M6	OBMC9K84T	182TC/184TC	INCHES	25.00	4.50	4.50	0.41	13.48	6.38	8.75	2.25	9.09
			MILIMETERS	635	114.3	114.3	10.4	342.4	162.1	222.3	57.2	230.9
M7	OBMC9V100E	IEC 100LC, B14 FACE	INCHES	25.39	3.94	5.51	0.47	12.97	6.06	9.44	N/A	8.03
			MILIMETERS	644.9	100.1	140	11.9	329.4	153.9	239.8	N/A	204

*Dimensions AC, O, XO and XP may vary depending on HP, Enclosure, Speed and Manufacturer.

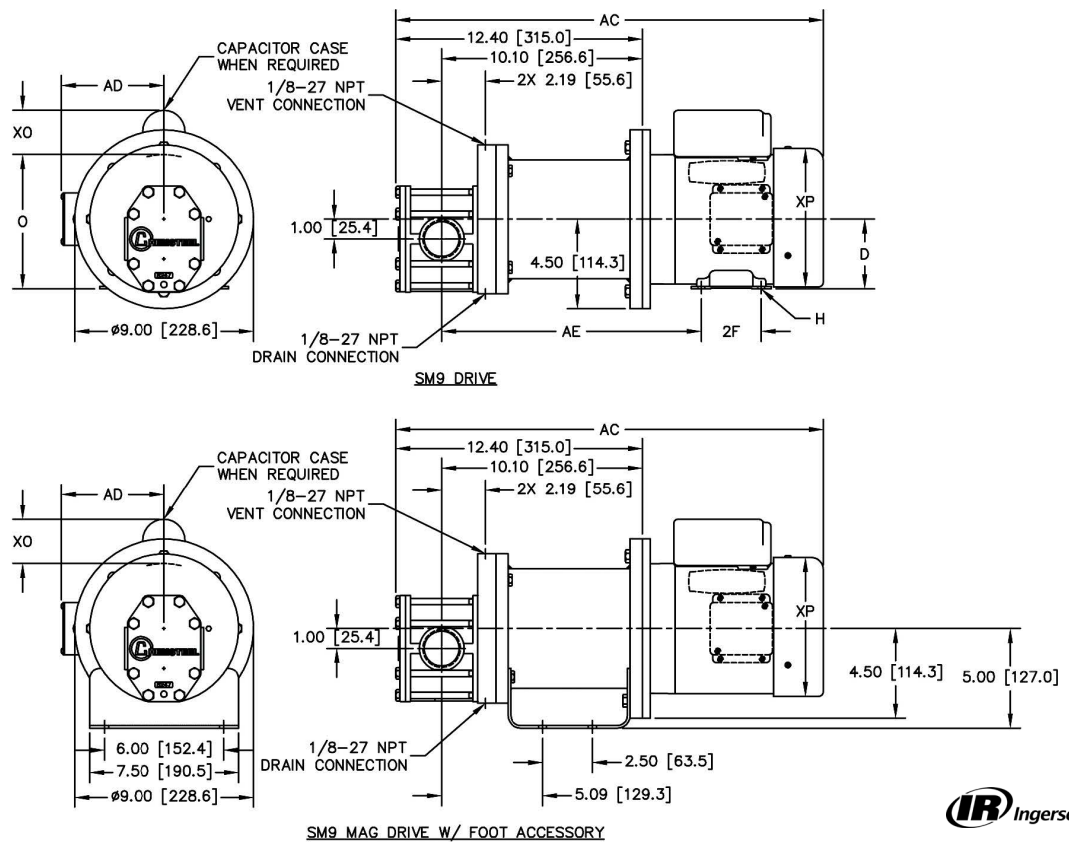

12500 South Pulaski Road
Alsip, IL 60803, USA
Phone (800) 448.1668